

I-phase low-voltage I,25- I 25kVA, IP00

Type 2LT-00

Open single-phase non short circuit proof transformers with power range from 1,25 to 125 kVA. Designed and tested according to norm EN61558-2-4, IEC60076 and IEC60726. Standard types designed as isolating transformers with separate primary and secondary windings. Degree of protection IP00. Accessories; Temperature control units with alarm or trip [TC], PT100 sensors [PT], RTD sensors [RTD].

Applications:

This is an ideal design for transforming voltage up or down, or for installations which require a galvanic partition between the primary and secondary voltage. E.g. electric motor, compressor, cooling plants, automatic washing machines, etc. Custom designed types with other voltages, frequencies, electrostatic shield between primary and secondary, regulations, tapings, transport wheels or other features are available on request.

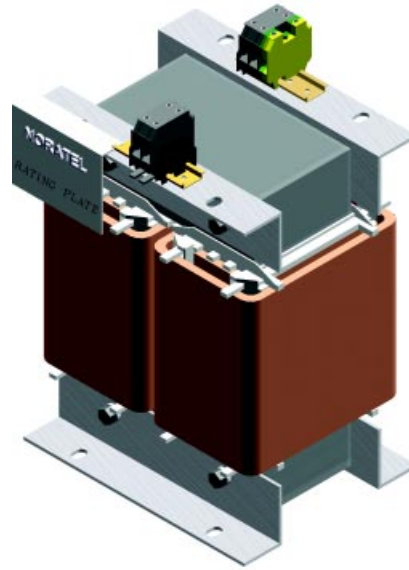

Wiring diagram

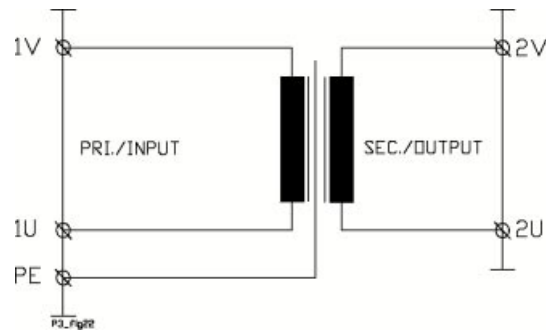

Technical specifications

- Input voltage: 115V to 1000V
- Frequency: 47-63Hz
- Output voltage: 115V to 1000V
- According to: EN61558-2-4, D.N.V., IEC60726 / IEC60076
- Test/insulating voltage: 3kV AC RMS
- Construction class: I (earth terminal)
- Insulation class: F (155°C) - standard
H (180°C) - option
- Ambient temp. (t_a): 45°C (D.N.V)
- Degree of protection: IP00
- Connections: - Terminal block
- Cu-bars

Noratel declare and guarantee that all transformers are designed according to the following standards; IEC60726, IEC60076, D.N.V., EN55014:1993 (EN55014-1:1997), EN61000-3-2:1995, EN61000-3-3:1995 EN55104:1995 (EN55014-2:1997), EN50081-1:1992, EN50082-2:1995 based on the following directives; L.V.D 73/23/EEC, 93/68/EEC, EMC 89/336/EEC, 91/263/EEC.

Dimensions

2LT1.25 - 2LT20

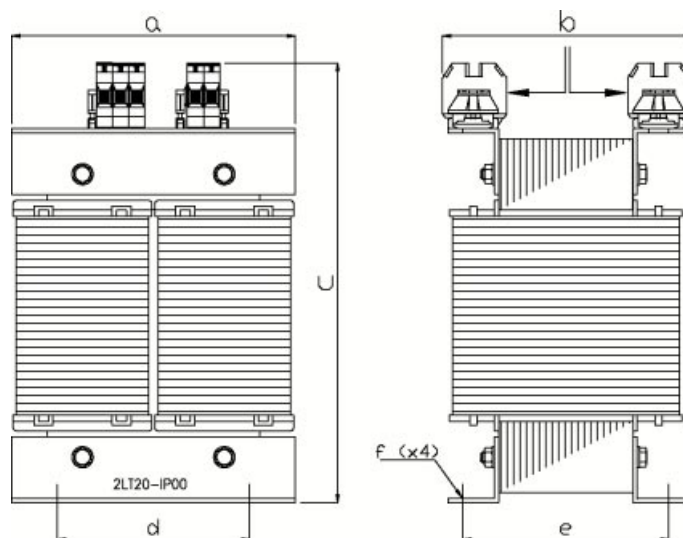

2LT25 - 2LT125

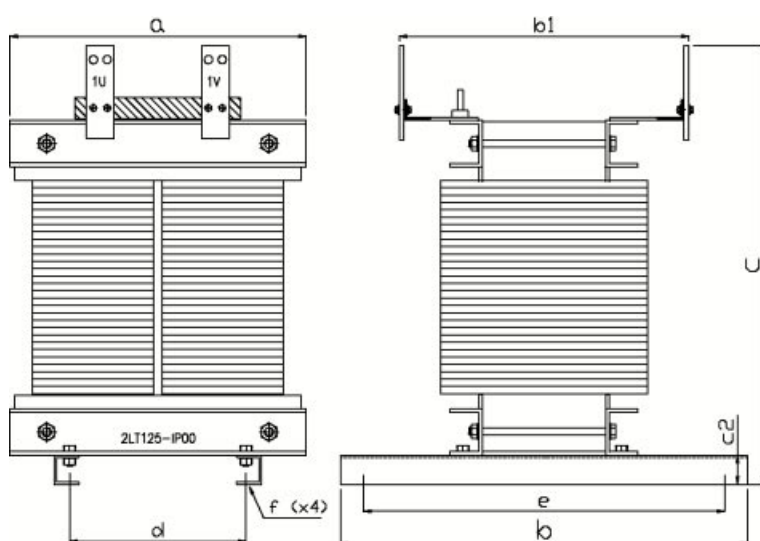

Standard types 2LT-00

Power (kVA)	Type	Dimensions (mm)								Weight (kg)
		Length a	Width b	Height c	<i>b1</i>	<i>c2</i>	<i>d</i>	<i>e</i>	<i>f</i> ^(ø)	
1.25	2LT1.25	152	150	255	-	-	100	95	7x13	15
2.0	2LT2.0	176	165	285	-	-	112	107	10x18	21
3.0	2LT3.0	200	185	325	-	-	124	119	10x18	28
4.0	2LT4.0	240	213	380	-	-	144	125	10x18	35
5.0	2LT5.0	240	228	380	-	-	144	140	10x18	42
6.3	2LT6.3	240	243	380	-	-	144	155	10x18	48
8.0	2LT8.0	280	240	440	-	-	176	143	12x18	55
10.0	2LT10.0	280	270	440	-	-	176	173	12x18	72
12.5	2LT12.5	280	300	440	-	-	176	203	12x18	90
16	2LT16.0	320	300	500	-	-	196	184	13x20	100
20	2LT20.0	320	330	500	-	-	196	214	13x20	128
30	2LT30.0	370	520	670	275	50	210	470	14,0	149
40	2LT40.0	410	520	720	285	50	210	470	14,0	167
50	2LT50.0	410	520	720	307	50	210	470	14,0	202
63	2LT63.0	490	630	860	345	100	250	580	18,0	246
80	2LT80.0	490	630	860	374	100	250	580	18,0	286
100	2LT100	570	700	940	375	100	290	650	18,0	373
125	2LT125	570	700	940	405	100	290	650	18,0	435