

Electrostatically shielded transformers

Type ISO

Specially designed single-phase perturbation attenuation isolating transformers with high transient suppression and low noise level. Designed and tested according to EN61558-2-19. ISO transformers are electro-statically shielded and have output filters which protect systems from unwanted "noise" and highfrequency voltages that can occur due to switching and loading on distribution lines. BS - for fixed installation, BP - portable installation.

Applications:

Designed to protect equipment that requires a low-noise voltage in order to work without problems e.g.: computer equipment, telephone exchanges and audio equipment.

Technical specifications

- Input voltage: 230V
- Frequency: 47-63Hz
- Output voltage: 230V (115-0-115)
- Attenuation effect: 120dB phase-ground
60dB phase-phase
- According to: EN61558-2-19
- Test/insulating voltage: 4kV AC RMS
- Construction class: I
- Insulation class: B (130°C)
- Ambient temp. (t_a): 40°C
- Degree of protection: IP20

Wiring diagram

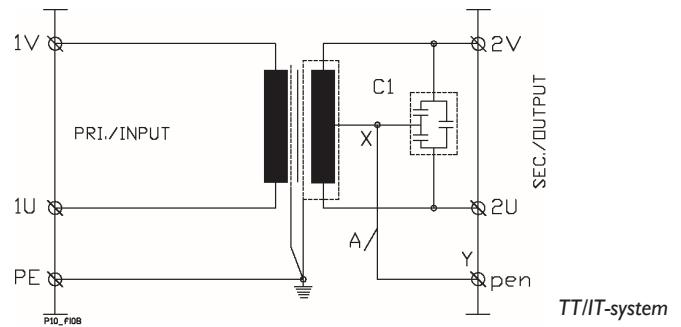

If a TN-system is preferable, point (A) can break so (Y) is directly connected to 2U. This will reduce the attenuation level.

Dimensions I-6, I-10, and I-14

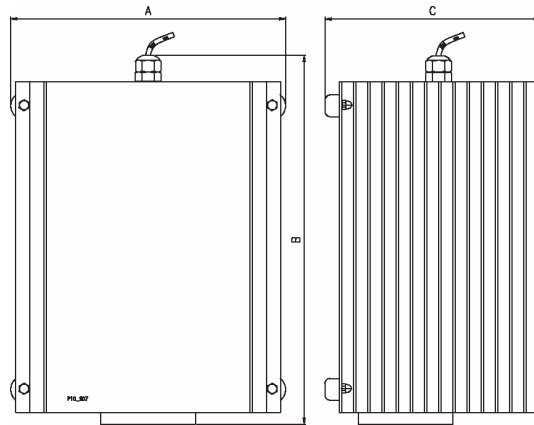

Dimensions I-20

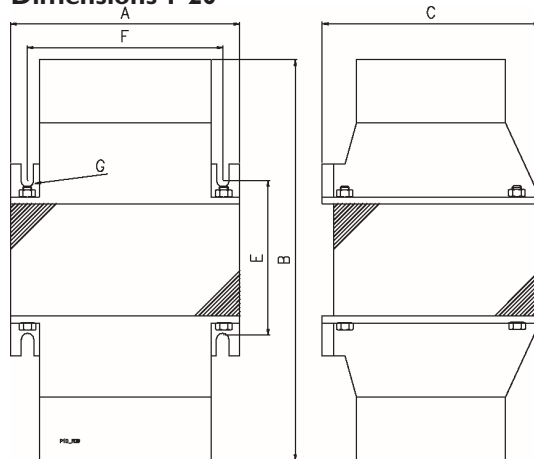

Standard types

Type	Voltage Sek. (V)	Current Sek. (A)	Power (VA)	Dimensions (mm)						Weight (Kg)	Art. no.
				A	B	C	E	F	G		
ISO I-6	230	6,5	1500	240	310	183	-	-	-	25,5	3-230-500061
ISO I-10BS	2x230	10	2300	320	250	200	-	-	-	32,0	3-230-000006
ISO I-10BP	2x230	10	2300	320	250	200	-	-	-	32,0	3-230-000007
ISO I-14BS	2x230	14,4	3300	320	250	200	-	-	-	32,0	3-230-000008
ISO I-14BP	2x230	14,4	3300	320	250	200	-	-	-	32,0	3-230-000009
ISO I-20	2x230	20	4600	232	420	233	210	203	ø10	52,0	3-230-500200

Losses and short circuit currents



LF-ISO



ISO 1-6, ISO 1-10, ISO 1-14,

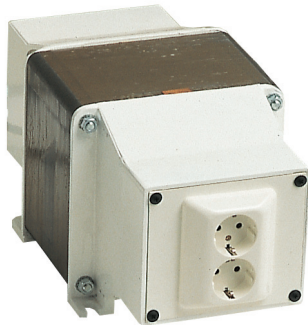

ISO 1-20



SST / ISO

Standard types

Type	FE-loss (W)	CU-loss (W)	e_z (%)	e_r (%)	I_c (xI_{nom})
LF-ISO					
LF 230-ISO	12	10	4,1	4,0	75
LF 460-ISO	19	19	4,2	4,1	55
LF 690-ISO	23	25	3,5	3,5	39
ISO					
ISO 1-6	63	33	2,5	2,4	70
ISO 1-10	46	68	3,2	3,0	24
ISO 1-14	60	114	3,7	3,5	22
ISO 1-20	56	65	1,8	1,4	40
SST					
SST 4.0	128	246	4,1	3,9	21
SST 6.3	168	294	3,4	2,9	19
SST 10	280	371	2,2	1,9	20
SST 16	387	496	2,6	2,0	15
SST 20	229	1108	3,3	2,8	18
SST 30	274	1063	2,8	2,1	18
SST 40	296	1567	3,3	2,5	15
SST 50	387	1564	2,8	2,0	14
SST 63	387	1564	2,8	2,0	14
SST 80	450	2291	3,5	2,3	13
SST 100	515	2415	2,8	1,9	13
ISO					
ISO 4.0	128	246	4,1	3,9	21
ISO 6.3	168	294	3,4	2,9	19
ISO 10	280	371	2,2	1,9	20
ISO 16	387	496	2,6	2,0	15
ISO 20	229	1108	3,3	2,8	18
ISO 30	274	1063	2,8	2,1	18
ISO 40	296	1567	3,3	2,5	15
ISO 50	387	1564	2,8	2,0	14
ISO 63	387	1564	2,8	2,0	14
ISO 80	450	2291	3,5	2,3	13
ISO 100	515	2415	2,8	1,9	13

- All data for guidance, subject to change.